

Fluorite Apochromat

FS-60C

INSTRUCTION MANUAL

TAKAHASHI

Thank you very much for your purchase of a Takahashi Fluorite Refractor FS-60C/SV. Your first view through your instrument will show you an amazingly high contrast image of stars over the full field of view, where stars are seen as fine points of light. You are now ready to enjoy your observation visually and photographically with your telescope.

In order to use your instrument in its highest possible capabilities, please read this instruction manual very carefully and familiarize yourself with all the functions that your instrument offers. All the instruments are strictly inspected before shipment. If there is anything wrong with your instrument, please contact your authorized Takahashi distributors.



WARNING

NEVER TRY TO OBSERVE THE SUN THROUGH ANY TELESCOPE WITHOUT PROPER FILTER. IT WILL CAUSE PERMANENT BLINDNESS. KEEP CHILDREN AWAY FROM ANY TELESCOPE DURING DAYTIME. EVEN A SMALL FINDER SCOPE CAN DELIVER SUFFICIENT AMOUNT OF LIGHT TO MAKE EYE BLIND.



CAUTION

- The objective has been collimated by highly trained factory technicians. If you feel this is necessary, please contact your factory authorized distributor.
- Keep the dew cap in place when your telescope is not in use. This will prevent dust from collecting on the objective.
- Should it become necessary to clean the outer surface of the objective, first remove all dust and grime particles with a hand power blower. Before you attempt to clean the surface, please contact your distributor for instructions. Then, gently wipe the surface with sterile 100% cotton moistened with lens cleaner.
- Never attempt to remove the objective from the lens cell. Doing so voids the guarantee. Contact your distributor and return it to them. They will make any necessary adjustments and return it to you.

Table of Contents

Warning & Caution	2
Table of Contents	3
Specifications	4
Tube Assembly Layout	5
Attaching Finder & Tube Assembly	6-9
Finder Alignment	10-11
Observation	12-15
Care & Maintenance	16
What is Fluorite	17
System Chart	18-19

SPECIFICATIONS

Effective Aperture	60mm
Focal Length	355mm
Focal Ratio	1: 5.9
Resolving Power	1.93"
Limiting Magnitude	10.7
Light Gathering Power	73X
Diameter of Main Tube	80mm
Total Length of Main Tube	440mm(FS-60C) 400mm(FS-60CSV)
Weight of Main Tube Assembly	abt. 1.4kg(FS-60C) abt. 1.4kg(FS-60CSV)
Finder Scope	6X30 8'

Tube Assembly Layout

FS-60C

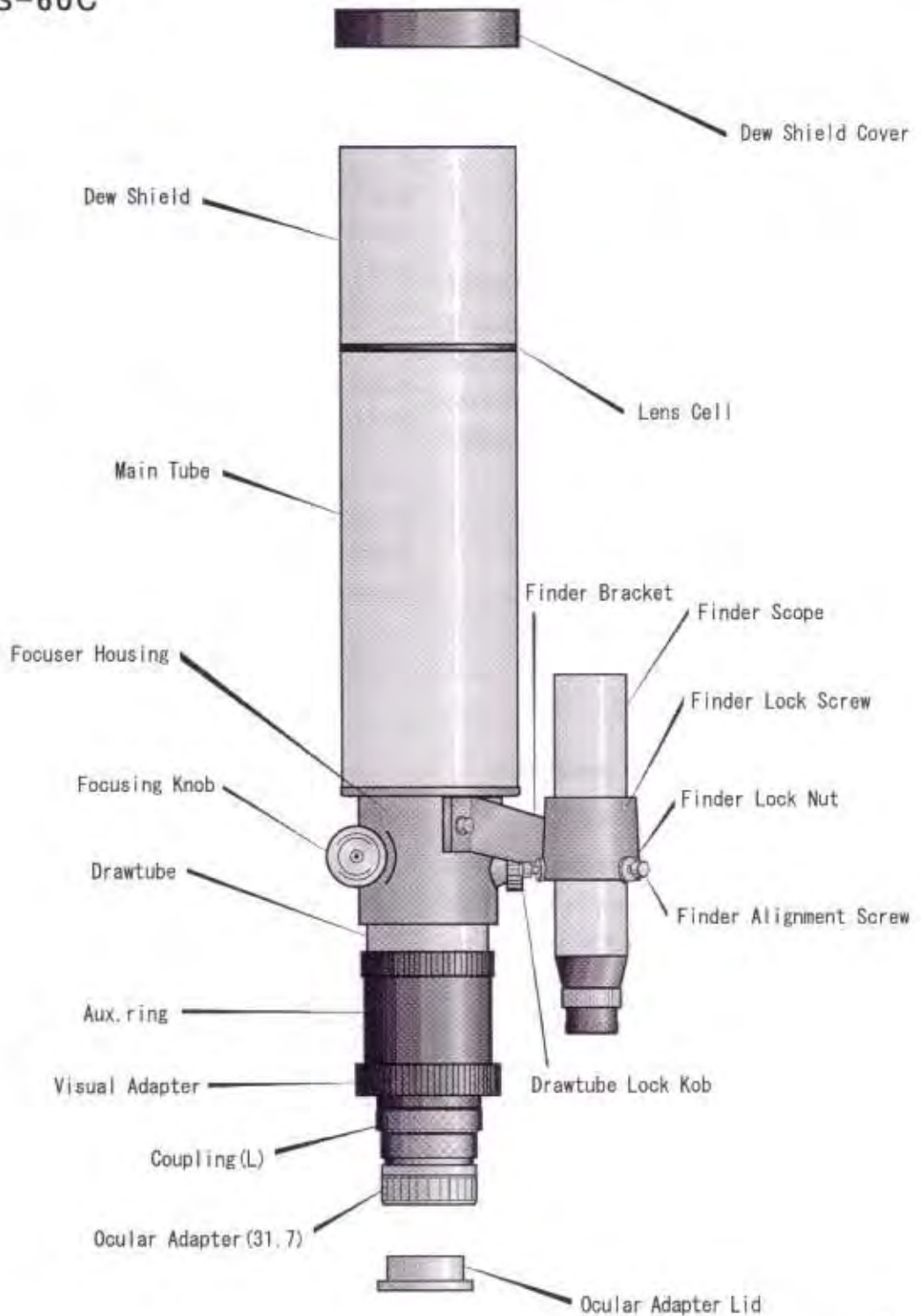

Fig. 1

Attaching The Finder And Tube Assembly

Your telescope is shipped with the finder unattached. Use the following instruction to assemble and align the finder.

■ Attaching The Finder Scope

Place the finder holder leg on the finder base on the tube assembly and lock it firmly with two cap-bolts provided. Set the finder as parallel to the tube as possible. Failure to do so will make alignment difficult. Refer to Fig.2,3.

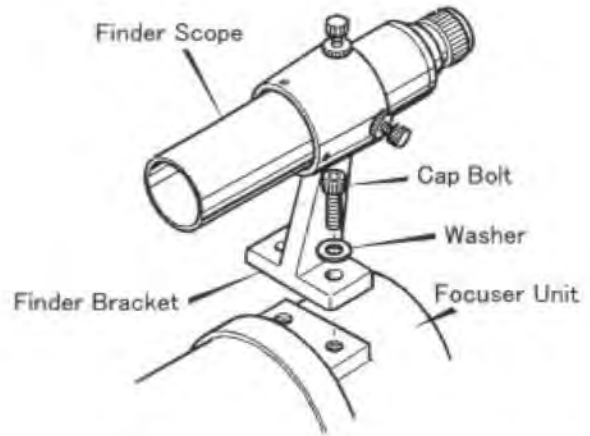

Fig. 2

■ Setting the main tube assembly onto the equatorial mount

Set the tube holder onto the head of the mount with two cap-bolts as in Fig.3 and lock the tube with a lock nut after balancing the tube. The tube holder can be used with all Takahashi mounts.

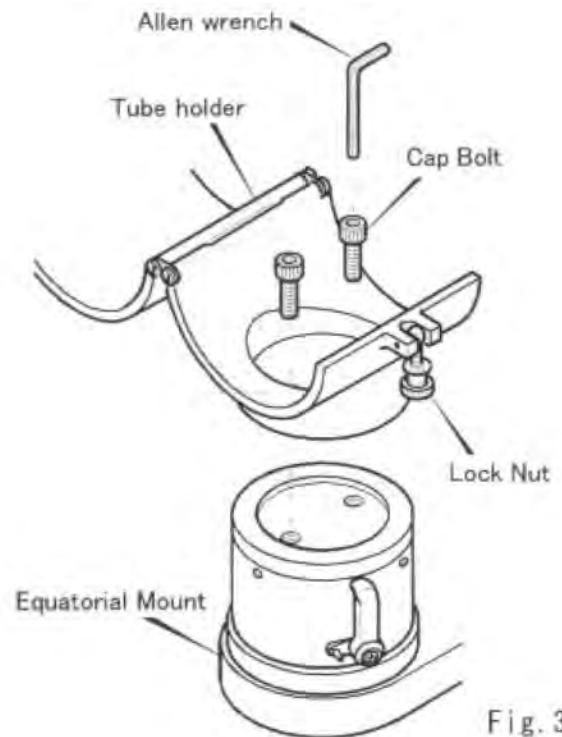

Fig. 3

The correct way to attach the tube holder to the mount is to use the two cap bolts provided. After an optical tube has been set into the tube holder, the next step is balancing. Refer to Fig.4.

Now that the instrument has been attached to the mount, it will be necessary to balance the load in the R.A. and the Dec.

The first step is to clamp the R.A. and unclamp the Dec. Hold the tube of the telescope in the event it is out of balance. Then, loosen the tube clamp slightly so that the tube can be moved in either direction. Move the tube in either direction until it balances. When the tube is balanced, tighten the clamp.

Next, loosen the R.A. clamp, and tighten the Dec. clamp. Unclamp the counterweight(s) and slide them in either direction until the package is balanced.

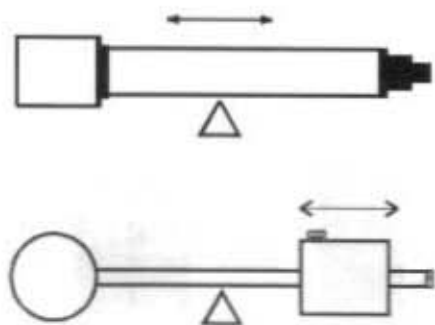

Fig. 4

■ Attaching the oculars

Remove the ocular adapter cover and loosen the lock ring by turning it counter-clockwise. Then, insert your desired ocular into the ocular adapter and lock the ocular by turning the lock ring clockwise. Refer to Fig. 5.

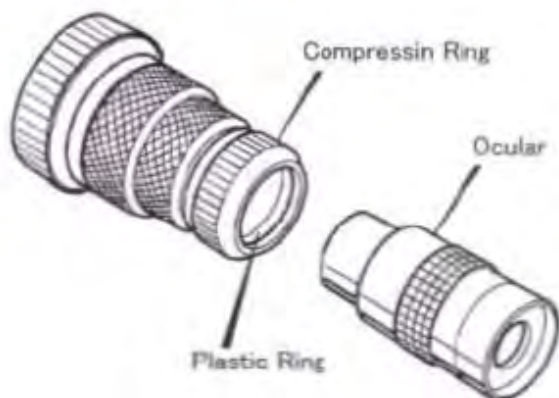

Fig. 5

■ Connecting System Parts

The adapters and the rings are provided on the visual back to connect various system parts. Carefully study the system chart in this book before connecting system parts.

Incorrect connection of the parts may prevent the telescope from coming to a sharp focus or any focus at all. Refer to Fig. 6.

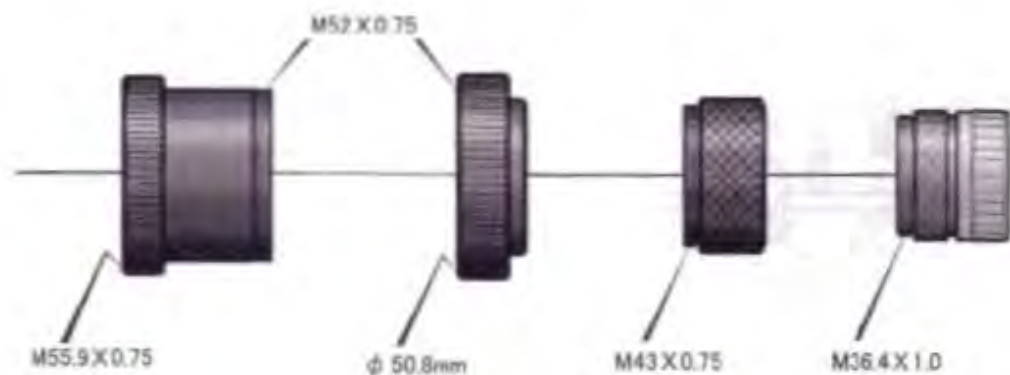

Fig. 6

■ Focusing

After inserting the ocular into the telescope, it is necessary to achieve the best possible focus. Remember the atmosphere will limit the highest magnification that can be used on any given night. Using the lowest power ocular, focus the image and then use successively higher magnification, until the desired magnification is achieved. This is particularly useful, if very high magnification will be used and will permit the continual centering of the object viewed. Please familiarize yourself with the following procedure.

● Focusing System

Focusing is made with a rack-and-pinion system. This system will permit rapid focusing. Turning the focusing knob backwards as arrowed will move the focuser out, and turning it in the other direction will make the focuser move in. Refer to Fig.7.

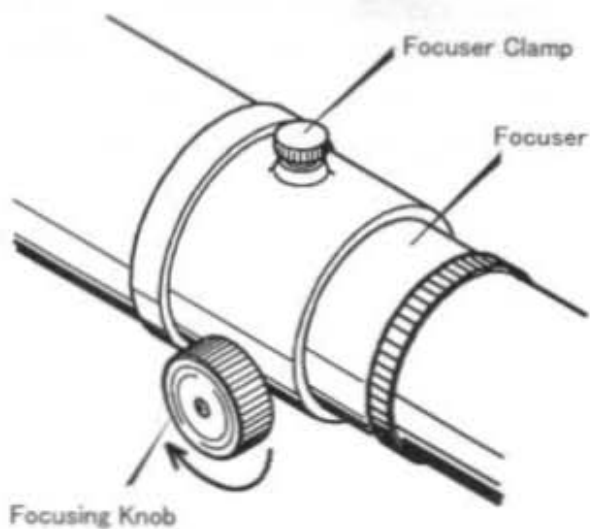

Fig. 7

● Focusing

Remove dew shield and ocular cover from the telescope. Insert the diagonal prism into the compression ring adapter at the end of the focuser and tighten it with a clockwise motion. Do not overtighten the ring. Then insert the ocular into the compression ring on the diagonal prism, repeating the process.

Use a brighter star at low power or an object in the daylight that is at least a mile away. You may place a small mark on the focuser tube as a reference. When you think you have achieved best focus, move the focuser in and out past focus then back to best focus of an object. As mentioned, start with low power and then proceed to higher power as desired. When a star is brought into critical focus, you may notice a bright and a dimmer ring around the star. This is the diffraction pattern of the star. This is not defect, but rather is a result of diffraction limited optics.

● Focuser Clamp

The focuser clamp can be used to lock your telescope at best focus. It is a good idea to use this lock when critical focus must be held for a long period when a heavy accessory such as a camera is attached. For visual use, it will be rare to use the lock. Remember to always loosen the lock before refocusing your telescope.

Finder Alignment



Before the finder is placed in the finder holder, use plastic clear tape and tape the finder with two layers to prevent the tube from being scratched by the front finder set screws.

A finder is a useful tool. It permits the precise centering of an object in the field of view. The 6.3° field of view allows the easy centering of an object to be viewed or photographed.

The Takahashi finder uses an interrupted crosshair which is designed to allow the easy centering of an object to be photographed or observed. The wide field of the finder makes the finding of an object easier, therefore, it is important that the finder and the telescope be in alignment. The following procedure can be used to align the finder.

◆ Alignment Procedure

1. Place a low power eyepiece in the telescope and center a bright star in a convenient part of the sky. Do not forget to engage the motor drive to keep the star centered. If this procedure is done in daylight, use an object that is at least one mile away. Loosen the lock nuts on the finder bracket and slightly move the star to the center of the field using the adjusting alignment screws.
2. Then use a higher magnification eyepiece and repeat the procedure by centering the object in the field of view of the telescope and then the finder. Continue this process until the highest possible magnification has been used.

◆ Adjusting Screw Procedure

1. Turn all the lock nuts until they reach the head of the alignment screws.

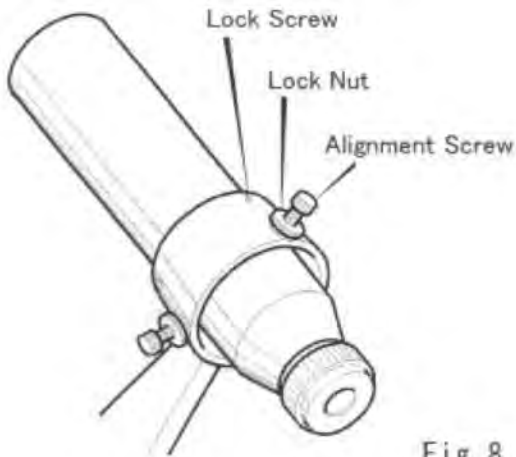

Fig. 8

2. In order to move the crosshair in the direction of the arrow, first loosen screw (a) and tighten (push) the finder with screw (c). This procedure will move the crosshair in the desired direction. The top of the finder will move in the opposite direction and the object will move in the direction of the smaller arrow. Refer to Fig.9.

3. In a similar fashion the direction of the movement of the finder is made by adjusting the three screws.

Learn the relationship between the movement of the three adjusting screws. If the finder cannot be moved in the desired direction, loosen the locking nuts.

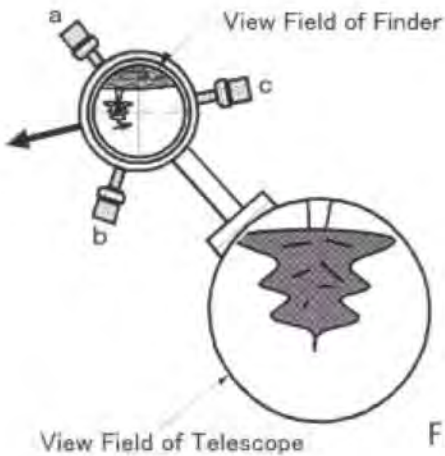

Fig. 9

Observation

■ Visual Observation

◆ Determining Magnification

The magnification of any ocular used with the telescope can be calculated by using the following formula.

$$\frac{(\text{focal length of a telescope})}{(\text{focal length of an ocular})}$$

Therefore, the shorter focal length oculars will produce the higher magnification. On some nights of exceptional seeing, it is a fun to use highest possible magnification to view the Moon and planets.

◆ Compression Ring Star Diagonals

A 90° diagonal prism is optionally available from Takahashi. This permits easy viewing of objects at the zenith. The 31.7mm standard diagonal prism is set into the compression ring adapter at the end of the telescope and then the ring is tightened just enough to hold the diagonal prism. Then, the ocular is placed in the compression ring on the prism and held by the same procedure.

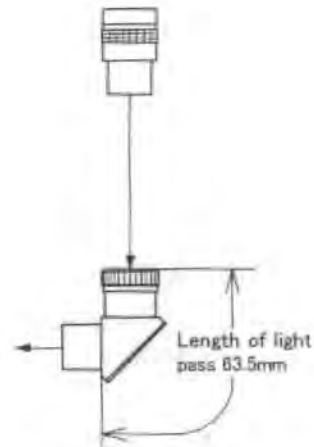

31.7 Prism Diagonal

Fig. 10

◆ Lunar observation

The Moon is an excellent object for beginners and advanced amateur astronomers as well. The entire Moon can be viewed at about 50X, but the Moon in the clear sky just before and after the full Moon is too bright so that be careful not to harm your eye by a long view of such Moon.

Using higher magnification on the Moon in any phase to see detail will allow the observer to see smaller and smaller detail, ray structures, and rilles. The high contrast images produced by the FS-60C/SV will amaze the observer.

◆ Planetary observation

The FS-60C/SV fluorite refractor is suited for planetary observation. Its high contrast and sharp images will reveal a wealth of detail. Planets are seen as very small images in the view field. So use the highest possible magnification on the night of the steadiest of seeing. View a star at the zenith and see how much the image appears to twinkle. If the star twinkles a good bit, the planets will look good at relatively low magnifications. On the otherhand, on nights when the twinkle is almost gone, push the instrument up to the highest possible magnification. Also these good nights will produce amazing photos with a digital camera.

◆ Observation for nebulae and star clusters

In general, observing nebulae and star clusters requires a low power, wide field ocular which will take advantage of the telescope's light gathering power. On the otherhand, observing globular clusters and small nebulae required high magnification. This is particularly true in cities with high brightness. High magnification will help reduce the sky background and hence improve the contrast necessary to view the object(s).

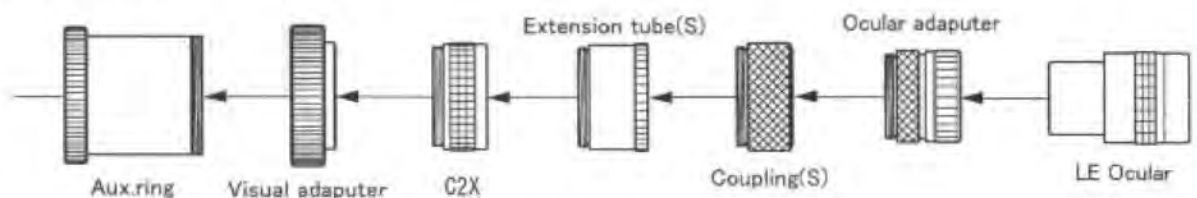

Fig. 11

■ Astrophotography

Focus is the most critical part of any astrophotography. Once critical focus has been achieved, then a fine astro photo can be made. Serious astrophotographers will always recheck critical focus before each photo is made.

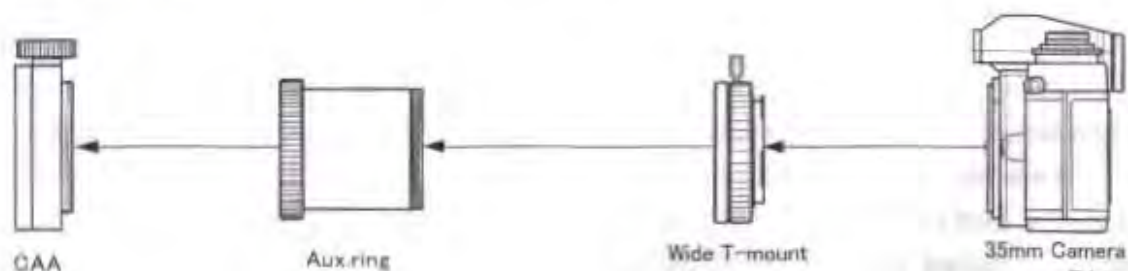

Fig. 12

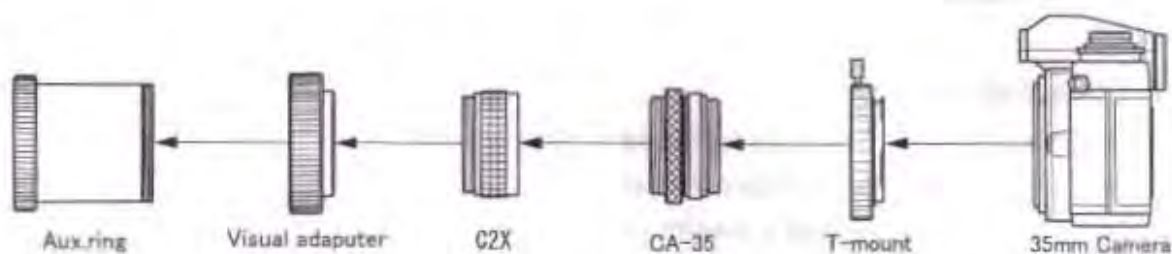

Fig. 13

◆ Eyepiece Projection Photography

When you want to take photos of the planets or the Moon, the TCA-4 is designed to make this easier. When the image of the planet is properly illuminated, then increase the magnification to the limit of the seeing.

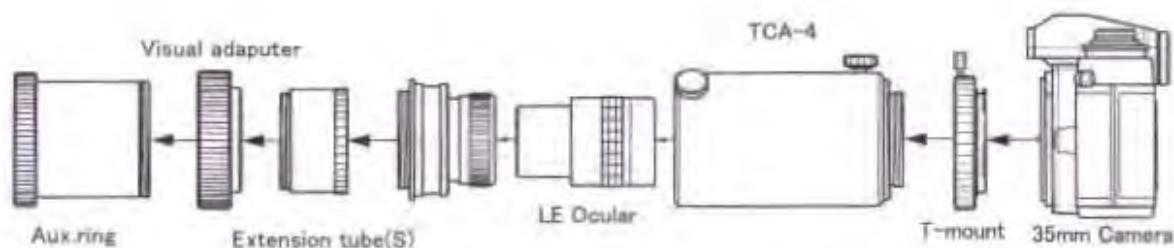

Fig. 14

◆ **Astrophotography with the Flattener**
By using the dedicated flattener with the connection shown below, you can take flat field astrophotos. See the system chart for connection.

When the FS-60C is used with the dedicated flattener, its optical specifications will be as follows.

Focal length 370mm
Focal ratio F6.2
Image circle 38mm (90% illuminated)

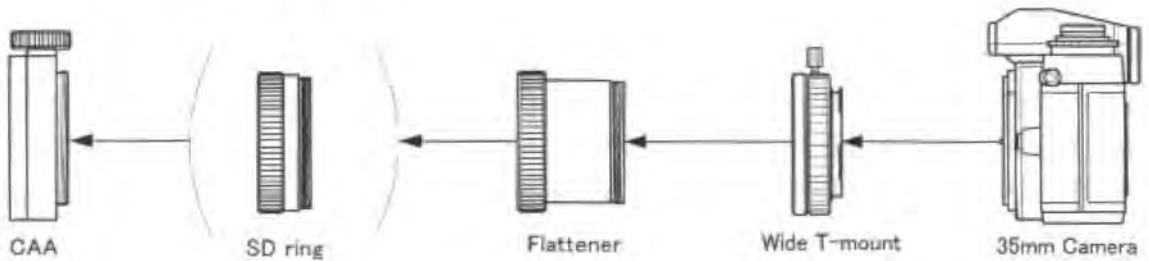

Fig. 15

◆ Seeing

It is important that high magnification images of the Moon and planets require good seeing. The method for determining the quality of seeing on a scale of 1 to 10, with 10 being perfectly steady seeing is to look to the zenith at a bright star. If it is twinkling rapidly, the seeing is between 1 to 4. If the twinkling is moderate, this is 5-6. If the star twinkles slowly to no twinkling, we have the 7 to 10 night. The less twinkle the better.

⚠ Cautions

When taking high magnification photographs of the Moon and planets, pay careful attention to balance. Rebalance the telescope when the object is placed in the center of the camera.

If the telescope is moved to another object, then rebalance it in the position in which the photos will be taken. Do not use the camera shutter.

Use the "hat trick" a black card place over the lens shade before the shutter is set on bulb. After the vibration has stopped, remove the black card for the duration of the photo, which will normally be in seconds.

Care & Maintenance

◆ The FS-60C/SV refractors have been precisely collimated at the factory by highly skilled optical technicians. In the event that as a result of a heavy blow, collimation is lost, please contact your distributor. They will collimate the instrument and return it to you.

◆ If the front lens of the objective has dust or dirt particles on it, use a large hand powered blower to remove the particles. Under no circumstances should dust be removed by any other means, rubbing the surface will cause scratches. If the lens must be cleaned, be certain that all dust and dirt particles have been removed by using a blower. Then, using cotton swabs slightly moistened with lens cleaner, gently clean the particles off.

◆ **REMEMBER, DO NOT USE ANY FORM OF CANNED AIR TO REMOVE THE PARTICLES.**

This product is very cold and could harm the front lens of the objective. Be certain that the dew cap is removed before attempting to clean the objective. Use the following procedure, if the front and rear surfaces of the objective must be cleaned.

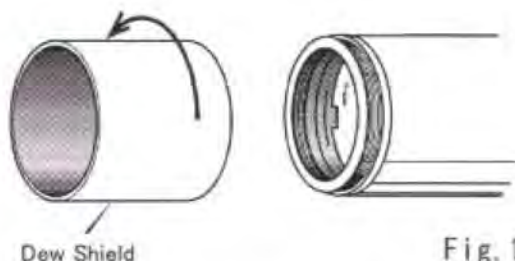

Fig. 16

Do not try to disassemble the lens cell for the lens cleaning. It will be impossible to collimate the objective without the special collimator.

If the telescope is used in condition of high humidity, be certain that it is taken indoors and dried out before it is stored. If the dew has not been dried and the instrument is stored, there will be a harmful residue left on the surfaces of the telescope. Leave the lens cap off until the objective lens is totally dried.

What is Fluorite?

Calcium fluorite (CaF_2) is a naturally occurring crystal. Its very low refractive index makes it the best of materials to use in the manufacture of apochromatic telescopes. Unfortunately, the natural crystal contains impurities and as a result, displays some properties that make it unsuited for use in a telescope.

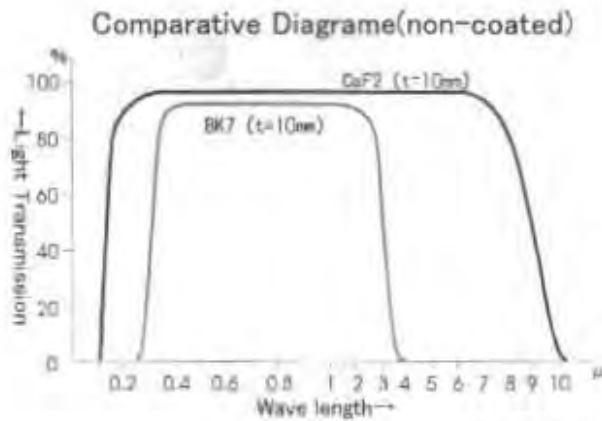

Fig. 17

Now thanks to modern technology, fluorite crystals are grown in an oven. This process produces a totally pure mono crystal structure that does not display any of the unsuitable properties of the natural crystal and has the same very low refractive index. Now, calcium fluorite crystal can be hard multi-coated for maximum light transmission and durability.

As the diagram shows, the band pass of fluorite of 1000 to over 100,000 angstroms eclipses by many magnitudes that of any optical glass. Additionally, the use of multicoatings further increases light trans-

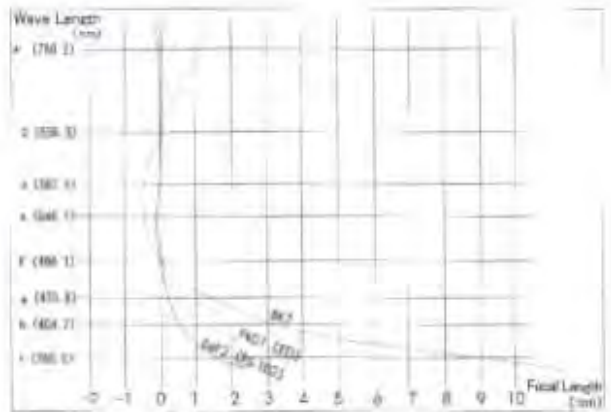

Fig. 18

mission over any ED glass. These features make the fluorite objective the premier photo/visual instruments for deep sky or lunar and planetary applications in their size class.

When the fluorite instrument is taken out for an observing session, it will take about 30 minutes for the objective to temperature equalize for maximum performance. This fact is also true for any optical system used.

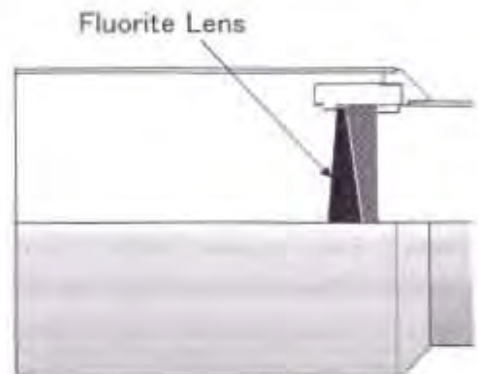
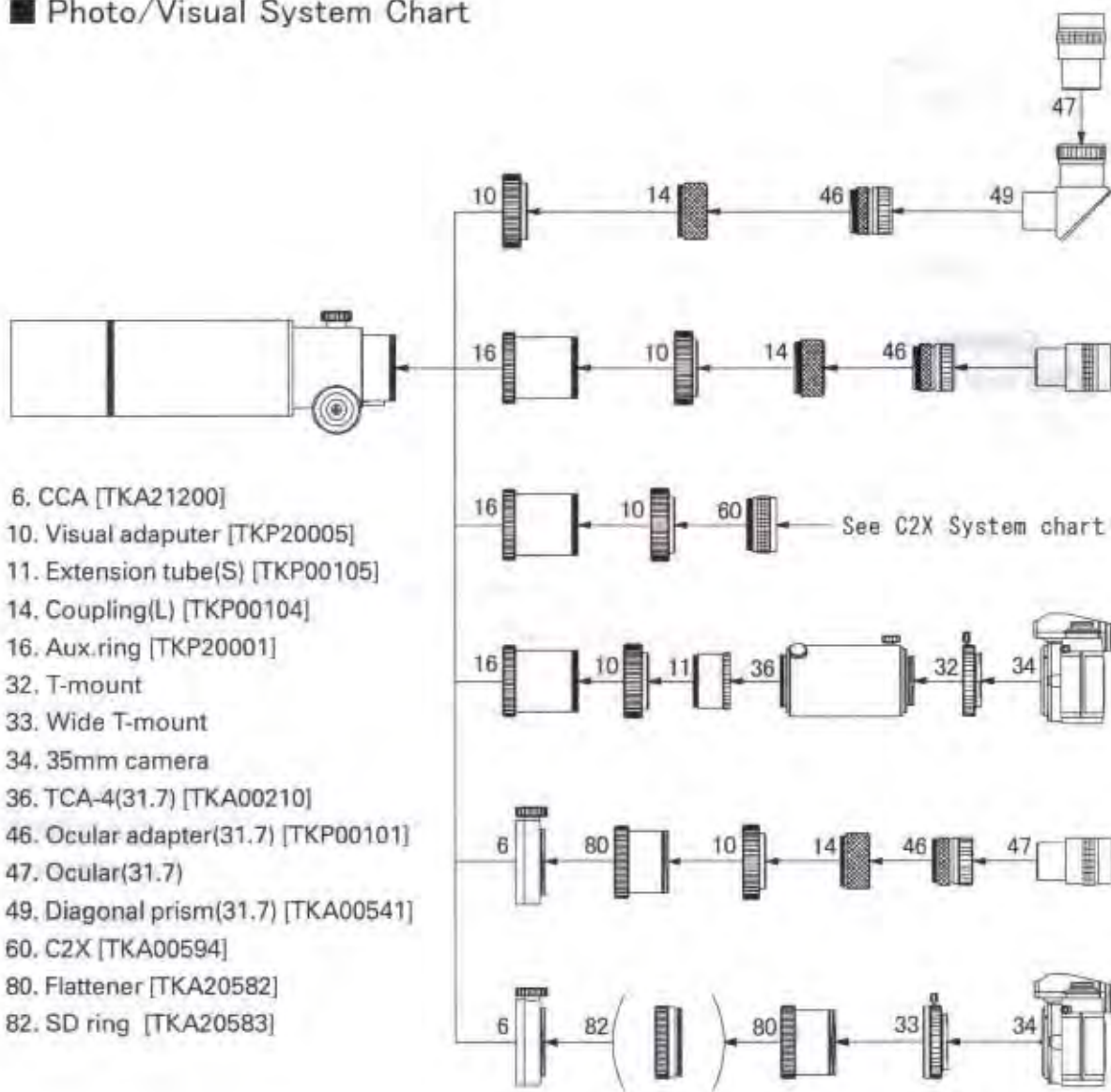

Fig. 19

System Chart

■ Photo/Visual System Chart



[Note 1] No.10,14,16,46 are standard with the tube ass'y.

[Note 2] Some types of 35mm SLR or digital SLR cameras might be not connected.

[Note 3] When the extension tube (No.82) is used, the FS-60C can focus the object in the distance of about 6m to infinity.

■ C2X System Chart

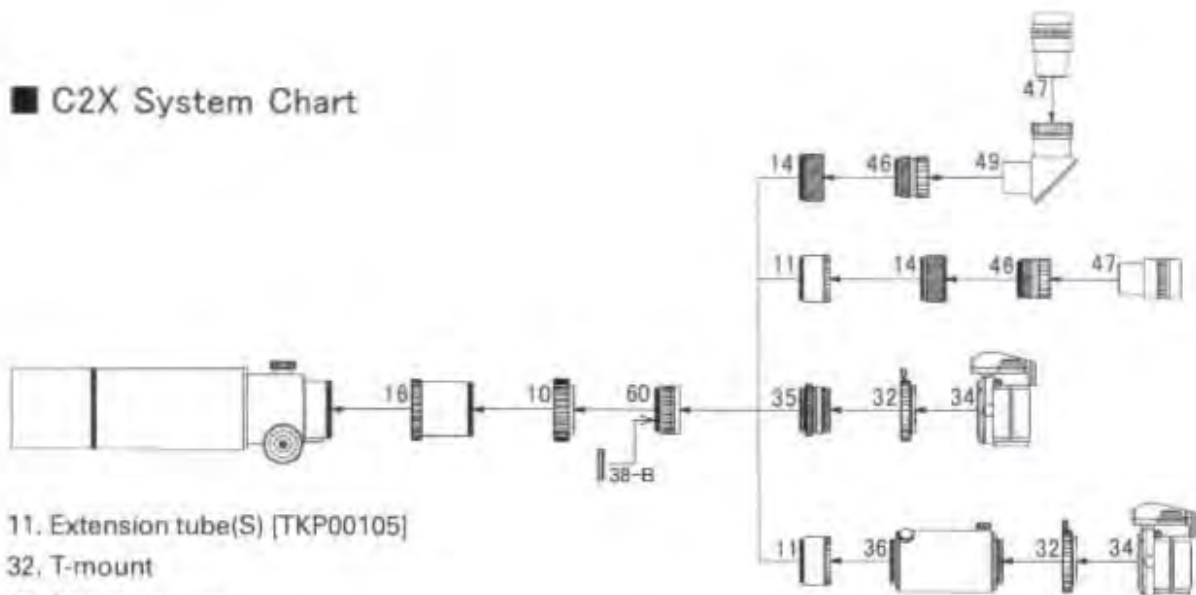

11. Extension tube(S) [TKP00105]

32. T-mount

34. 35mm camera

36. TCA-4(31.7) [TKA00210]

38-B. Filter ϕ 30.5mm

46. Ocular adapter(31.7) [TKP00101]

47. Ocular(31.7)

49. Diagonal prism(31.7) [TKA00541]

60. C2X [TKA00594]

■ FS-60CSV Flattener System Chart

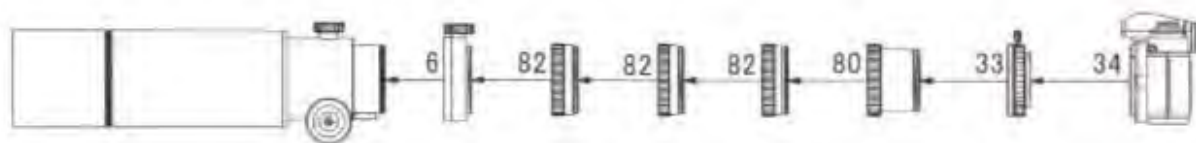

6. CCA [TKA21200]

33. Wide T-mount

34. 35mm camera

80. Flattener [TKA20582]

82. SD ring [TKA20583]

*When used SD ring(X3), FS-60CSV can focus in distance from 6 meters to infinity.
In case of FS-60C, it can focus in the distance from 6 meter to infinity with a SD ring.